

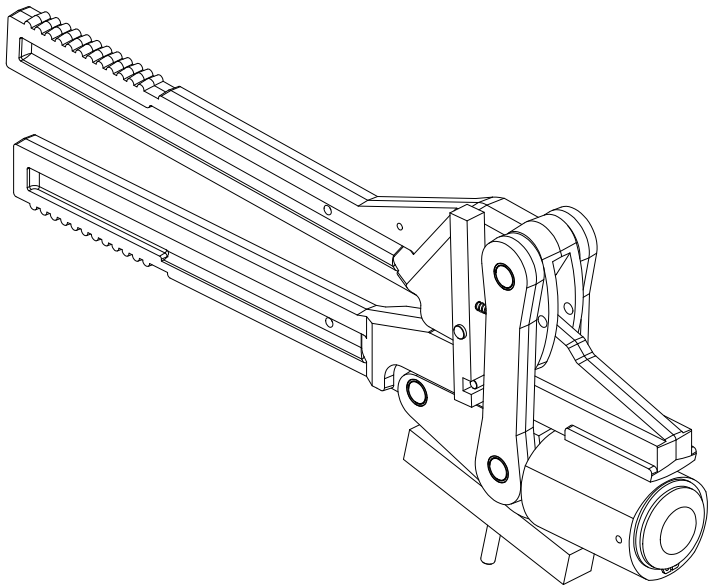

PE Pipe Squeeze-off Tool Model TC2SR



Instruction Manual



For your personal safety READ and UNDERSTAND instructions before using tools.
SAVE these instructions for future reference.

SPECIFICATIONS

*Table 1 : Squeeze-off Tool for 1/2" CTS to 2" CTS (12.7mm CTS - 51.8mm CTS)
 & 1/2" IPS - 2" IPS (12.7mm CTS - 51.8mm CTS) PE Pipe **



NOTE

Length:	24.0 in **	61.0 cm **
Width:	11.0 in	27.9 cm
Weight:	12.0 lbs	5.4 kg

* Manufacturer reserves the right to change specifications without notice.

** Additional handle extensions may be added to increase the reach of the tool.

TC2SR DIAGRAM

- A1 – Top Jaw / Bottom Handle
- A2 – Top Handle
- A3 – Bottom Jaw
- A4 – Links
- A5 – Rotating Jaw Sleeve
- A6 – Safety Locking Bar
- A7 – Slow Release Nut
- A8 – Slow Release Threaded Rod

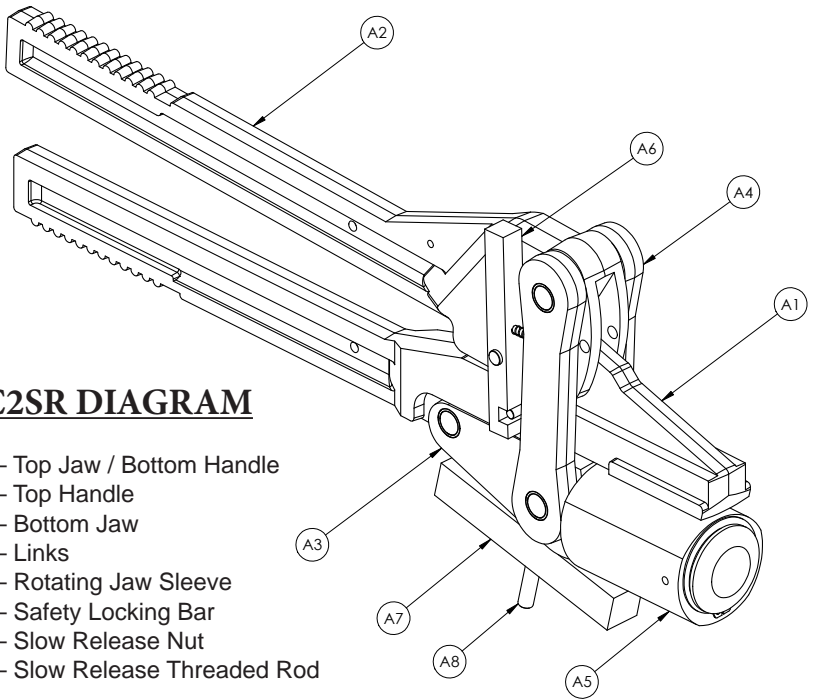

NOTE

Familiarize yourself with all parts, names, and numbers. Refer to this diagram for the assembly and operation procedures that follow.

INTRODUCTION

Timberline squeeze-off tools are designed to temporarily stop the pressurized flow of liquid or gas in polyethylene (PE) pipe.

Squeeze-off is a technique used to control the flow of gas or liquid in polyethylene pipe by compressing the pipe between parallel bars until the inside surfaces make contact. The flexibility and toughness of most polyethylene pipes allow the pipe to recover from a properly made squeeze-off without a measurable loss in service life. Squeeze-off is useful for making installation tie-ins and emergency repairs.

Timberline squeeze-off tools are made from high strength aluminum for superior durability and will not bend or break under normal use. However, care must be taken to ensure that the pipe is free of foreign material and the pipe setting on the rotating sleeve matches the diameter and SDR of the pipe to be squeezed.

Please read the following suggested procedure for squeezing off polyethylene plastic pipe using Timberline Squeeze-off Tools.

GENERAL SAFETY RULES

For all Tools

READ and UNDERSTAND all instructions. Failure to follow all instructions listed below may result in serious personal injury and/or damage to the tool.

The following ASTM standards provide guidance and requirements for squeeze-off tools, operating procedures, and qualification procedures.

- ASTM F1041, "Standard Guide for Squeeze-off of Polyolefin Gas Pressure Pipe and Tubing"
- ASTM F1563, "Standard Specification for Tools to Squeeze-Off Polyethylene (PE) Gas Pipe or Tubing"
- ASTM F1734, "Standard Practice for Qualification of a Combination of Squeeze Tool, Pipe, and Squeeze-Off Procedures to Avoid Long-Term Damage in Polyethylene (PE) Gas Pipe"

SAFETY INSTRUCTIONS

SAVE THESE FOR FUTURE REFERENCE

Static Electricity Safety



WARNING

Use a proper grounding rod at all times to insure personal safety.

PE pipe is a relatively low conductor of electricity. As a result PE pipe does build up a static charge when it is in gas service due to the gas flow on the inside of the pipe. During squeeze-off a larger amount of static charge builds up.

In addition to the potential for pipe damage due to static discharge, the build up of a static charge represents an ignition source. Timberline Tool recommends that you follow all of your company grounding techniques and that all personnel involved in squeeze-off operations receive training on those grounding procedures so that they understand the hazards involved.

Workplace Safety



CAUTION

Prior to using any squeeze-off tool, consult ASTM Standards F1041-02, F1563-01 and F1734-03.

Always follow applicable company and OSHA safety procedures.

Observe pipe manufacturers' recommendations and precautions for squeeze-off of polyethylene pipe, exercising particular caution when leaking gas is present.

Safety first. Timberline squeeze-off tools must be used by qualified, trained personnel only and must never be left on the pipe unattended. Refer to pipe manufacturers' recommendations for locating squeeze-off distances from fittings and joints.

Personal Safety



WARNING

Stay Alert, watch what you are doing, and do not use tools while tired or under the influence of narcotics, alcohol, or medication.

Use proper clothing, eye protection, and safety equipment when using squeeze-tools.

A moment of inattention while operating squeeze-off tools may result in personal injury.

Store idle tools out of reach of children and other untrained persons.

Specific Tool Safety



If you have used other Timberline products please be aware that the operation of this tool may differ from others and that you may need to follow different rules. Always consult the manual to insure you are following the correct safety instructions to avoid personal injury.

Tool Usage Safety

Do not force the tool to perform a squeeze-off. The tool will operate safer and better if the rate of squeeze in these instructions is followed.

Maintain the tool with care. A properly maintained tool will be less likely to cause damage and is easier to control.

Check for misalignment, binding of parts, breakage of parts, and other conditions that might affect the operation of the tool. Accidents may be caused by improperly maintained tools.

Always use the Timberline TC2SR with the grounding rod inserted in the ground when working with natural gas, or any other flammable substance.

Use only the accessories or extension handles that correspond to your product. Accessories specific for one tool may be hazardous if used on a different tool.

Failure to use the TC2SR in the manner specified in this manual may result in injury and/or permanent damage to the tool.

This tool complies with ASTM F1563-01.



Always make sure to use the setting on the rotating sleeve that corresponds to the pipe size and SDR or wall thickness of the pipe to be squeezed-off.

Tool Service Safety



Tool service must only be performed by qualified repair personnel. Service or maintenance performed by unqualified personnel could result in a risk of injury.

OPERATING PROCEDURE



Remember this is only a recommended procedure for a safe and effective squeeze-off. Always follow your specific company safety rules when working around natural gas.

1. Ground the tool with the **Grounding Rod**. (*Fig 1*)

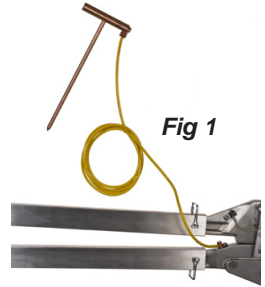

Fig 1

2. Turn the **Slow Release Nut** counter clockwise until it is close to the end of the **threaded rod**, so the jaw can completely open. (*Fig 2*)

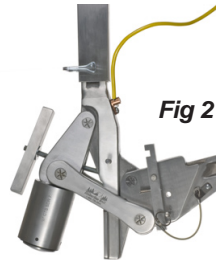

Fig 2

3. Rotate the **Jaw Sleeve** so the correct pipe size lines up with the pipe size indicator arrow shown on the **Tool Link**. (*Fig 3*)

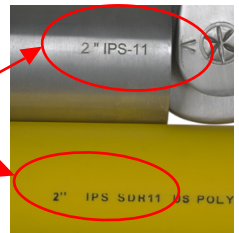

Fig 3

4. Install the 36" extension handles on the tool and secure with the locking pins. (*Fig 4*)



Fig 4



Make sure the pipe is clear of any debris, rock, dirt, etc.

5. Disengage the **Safety Locking Bar** and place the **Quick Release Pin** in the hole through the Top Handle labeled UNLOCK. (*Fig 5*)

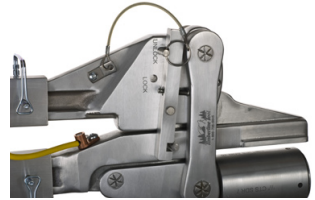

Fig 5

6. Open the tool and place over the pipe until the **Tool Links** are tight against the pipe. (*Fig 6*)

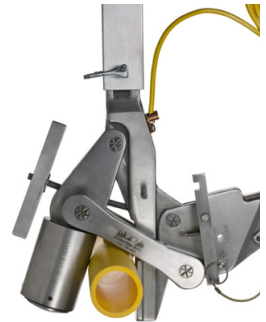

Fig 6

7. Engage the **Safety Locking Bar** by moving the **Quick Release Pin** from the UNLOCK position to the LOCK position. (*Fig 7*)

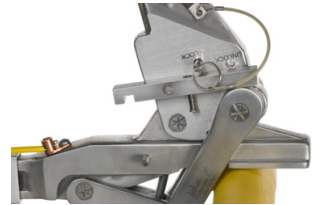

Fig 7



NOTE

Make sure the tool is perpendicular to the pipe during squeeze-off.

8. Close the handles until the tool goes over center and the flow is controlled. (*Fig 8*)



NOTE

Squeeze-off is complete when the notch in the **Safety Locking Bar** snaps over the pin.

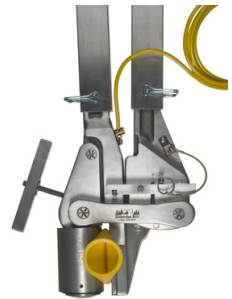

Fig 8

9. Turn the **Slow Release Nut** clockwise until it is tight against the bottom jaw. (Fig 9)



Fig 9

10. Place a lock-out/tag-out through the holes in the **Tool Link** to prevent accidental release of the tool during service operations. (Fig 10)



Fig 10

11. When it is safe to remove the tool from the pipe, disengage the **Safety Locking Bar**, move the **Quick Release Pin** from the hole marked "LOCK" to the hole marked "UNLOCK" and remove any lock-out/tag-out devices. Open the handles slowly until you feel the tool go back over center.
12. To control the rate of release, turn the **Slow Release Nut** counter clockwise at a rate of 10 rotations per minute according to ASTM Standards for release rate of 1/2" per minute. (Fig 11)

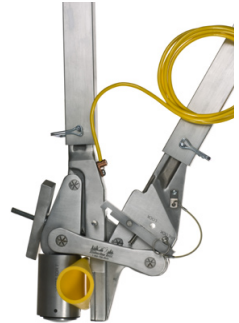

Fig 11



If recommended, re-round the pipe according to instructions provided by the manufacturer. Mark the location to avoid a future squeeze at the same location.

SERVICE

After every 10 uses:

1. Lubricate the pins and bushings with light oil. (**Fig 12**)



Fig 12

2. Lubricate the rotating jaw sleeve with a small amount of light oil. (**Fig 13**)



Fig 13

Misuse and extended service may lead to permanent damage or insufficient squeeze-offs. To ensure continued reliable squeeze-off using the Timberline TC2SR, it is recommended the tool be checked annually by measuring the gap of the tool, and/or performing a test squeeze on a pipe pressurized with air.



NOTE

If you have questions, please feel free to contact our customer service representatives at 1-800-735-6845 or by email at service@timberlinetool.com.

ACCESSORIES



WARNING

Any accessories or attachments recommended for use with your Timberline Tool are specified in this manual. The use of any other accessories or attachments might present the risk of injury. Only use accessories or attachments for their stated purpose.

TIMBERLINE LIMITED WARRANTY

Warranty Policy

Every product manufactured by Timberline Tool is thoroughly inspected and tested before leaving the factory. Our products are warranted to be free of defects from workmanship and materials for the period of ONE YEAR from the date of original purchase. Should any trouble develop on our tools, handles, or accessories during this one-year period please call 800.735.6845 to obtain return authorization for repair. If inspection shows the trouble is caused by defective workmanship or material, Timberline Tool will repair or, at our option, replace the product without charge.

This Warranty does not apply where:

- Repairs have been made or attempted by others.
- Repairs are required because of normal wear and tear.
- The tool has been abused, misused, or improperly maintained.
- Alterations have been made to the tool.

IN NO EVENT SHALL TIMBERLINE TOOL BE LIABLE FOR ANY INDIRECT, INCIDENTAL OR CONSEQUENTIAL DAMAGES FROM THE SALE OR USE OF THE PRODUCT. THIS DISCLAIMER APPLIES BOTH DURING AND AFTER THE TERM OF THIS WARRANTY.

TIMBERLINE TOOL DISCLAIMS LIABILITY FOR ANY IMPLIED WARRANTIES, INCLUDING IMPLIED WARRANTIES OF "MERCHANTABILITY" AND "FITNESS FOR A SPECIFIC PURPOSE," AFTER THE ONE-YEAR TERM OF THIS WARRANTY.

This Warranty gives you specific legal rights, and you may also have other rights which vary from state to state. Some states do not allow the exclusion or limitation of incidental or consequential damages, so the above limitation or exclusion may not apply to you. Some states do not allow limitation on how long an implied warranty lasts, so the above limitation may not apply to you.

This page intentionally left blank



Timberline Tool™

800-735-6845



(406)755-4258



(406)257-2711

www.timberlinetool.com

90 Conestoga Ct. Kalispell, MT 59901 USA